

Carlton®

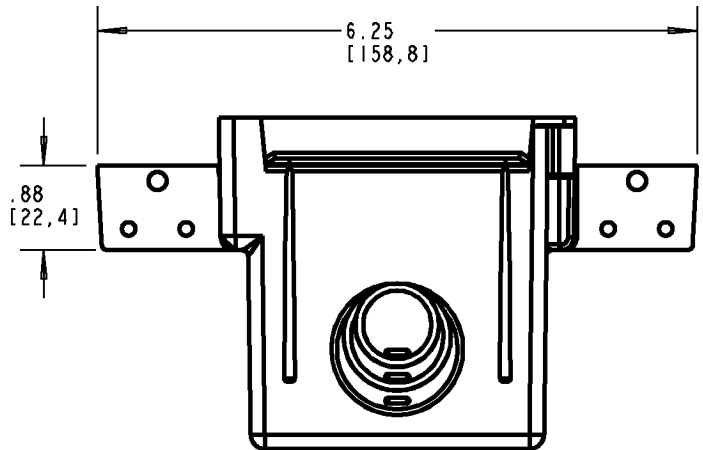
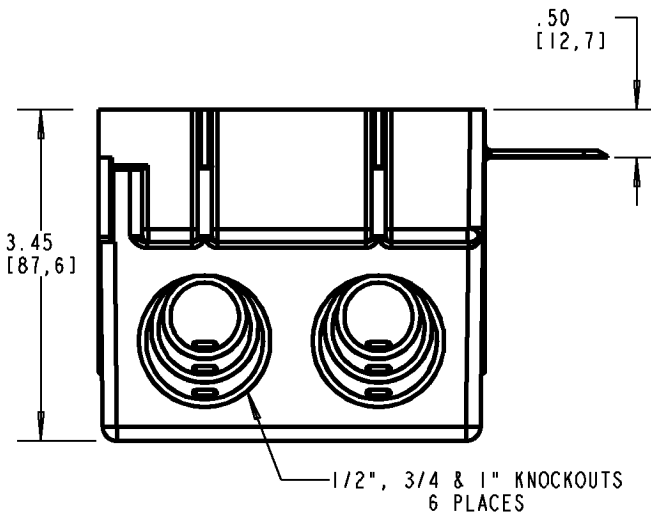
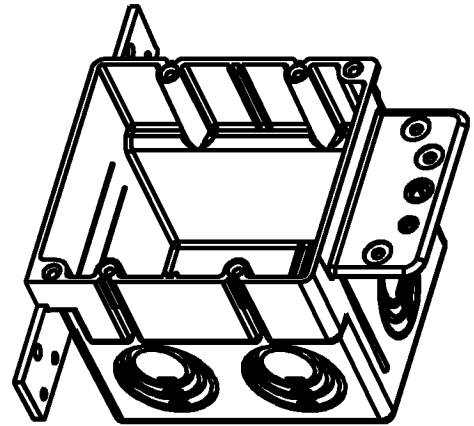
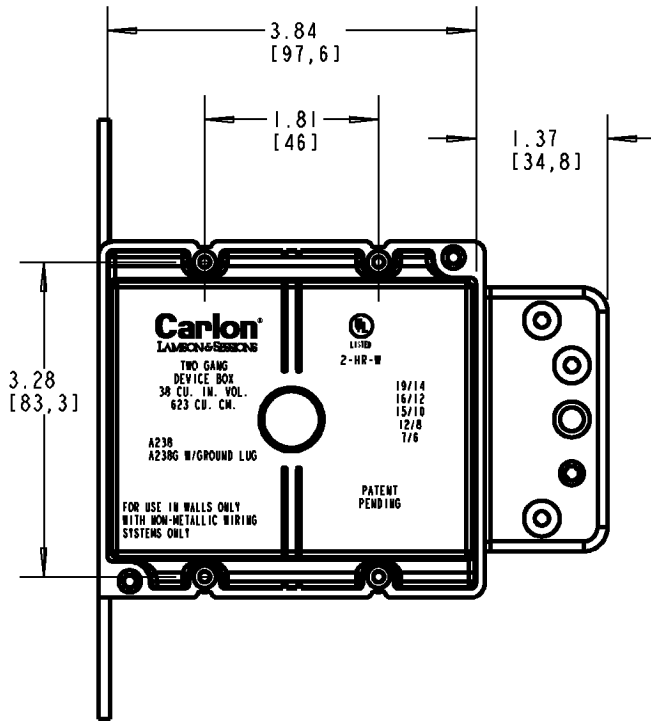

- NOTES:
1. PRODUCT IS UL LISTED.
2. MATERIAL: BLUE PVC

P/N
A238
A238-CAR

GENERAL NOTES

- ALL DIMENSIONS ARE FOR REFERENCE ONLY.
- DIMENSIONS IN BRACKETS [] ARE IN METRIC UNITS.

REVISIONS

*** SEE ERN (****) FOR APPROVAL SIGNATURES & RELEASE DATE.
PROJECT NO: ****

Thomas & Betts
www.tnb.com

DESCRIPTION: ENT 2 GANG DEVICE BOX

ORIGINAL PROJECT NO / (ERN NO)
/ ()

SHEET NO:
1 OF 1

REV. NO:
C

DRAWING NO:
WSD-AC04385