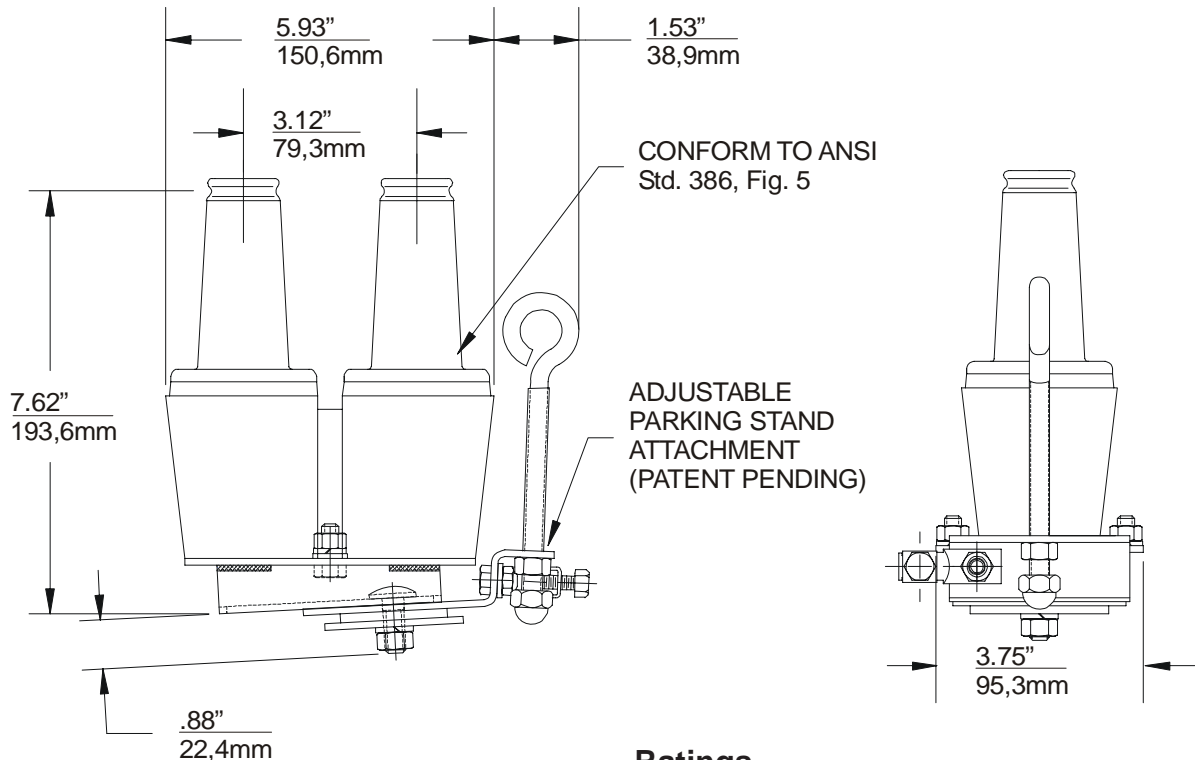

PRODUCT SPECIFICATION SHEET
I T C
15kV 200A Loadbreak Feed-Thru 2
164FT2-AB

The 164FT2-AB feed-thru is a fully shielded, fully submersible, separable insulated connector designed for energized operation. It is suitable for use on 15kV class loadbreak systems. When used in conjunction with 15kV class elbow connectors, the 164FT2-AB provides the circuit with the loadbreak junction point. Testing and grounding of the circuit is accomplished when the 164FT2-AB is used in conjunction with the 370TR and 160GLR. When used in conjunction with a 160DR, the 164FT2-AB can be used to isolate and "dead-end" the circuit. The 164FT2-AB adjustable bracket allows the parking stand attachment to be adjusted left and right and the feed-thru tilt to facilitate the best operating placement. The 164FT2-AB will function as either a 164FT or a 164FTV. The 164FT2-AB is designed to mate with the following Elastimold products:

- 165LR/166LR elbow connector
- 370TR test rod
- 160GLR grounding elbow
- 160DR/DRG & 167DR/DRG insulated cap

Ratings

per ANSI/IEEE Standard 386
 15kV Voltage Class
 8.3kV Max Phase-to-Ground - Operating Voltage
 14.4kV Max Phase-to-Phase
 95kV BIL - Impulse Withstand (1.2 x 50 microsecond wave)
 34kV AC - One Minute Withstand
 53kV DC - 15 Minutes Withstand
 11kV AC - Corona Extinction @ 3pC Sensitivity
 200 Amp - Continuous and Loadbreak
 10kA Sym - 10 Cycles Momentary & Fault Close

Ordering Instructions:

To order, specify number **164FT2-AB** feed-thru

The 164FT2-AB feed-thru includes the following:

1 - Feed-thru body	164FT2-AB
2 - Protective shipping caps	1601-APC-1
2 - Lubricants	82-08
1 - Installation instruction	IS-1102