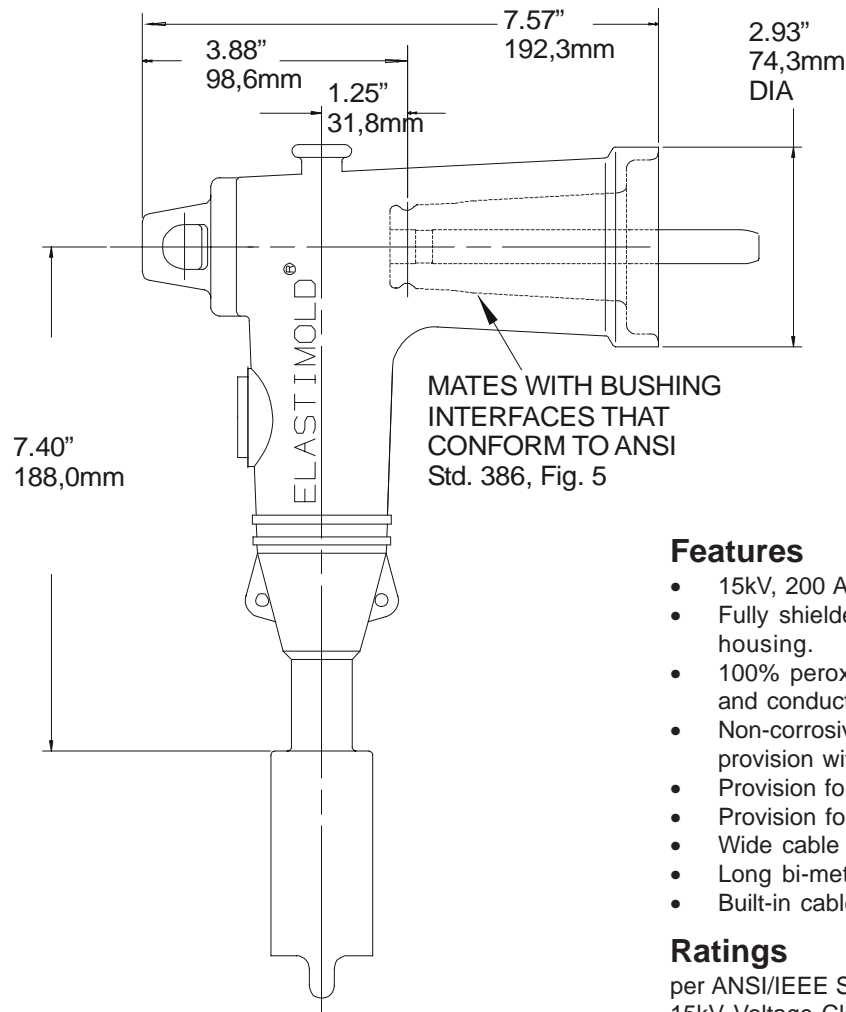

PRODUCT SPECIFICATION SHEET
I T C
15kV 200A Jacket Seal Loadbreak Elbow
165LRJS-WX
(w/O Test Point)

Features

- 15kV, 200 Amp Loadbreak Elbow
- Fully shielded, fully submersible molded rubber housing.
- 100% peroxide-cured construction includes insulation and conductive EPDM materials.
- Non-corrosive, capacitively coupled voltage test point provision with removable protective cap.
- Provision for hot stick operation.
- Provision for ground wire connection.
- Wide cable range with minimum number of sizes.
- Long bi-metal compression lug is standard.
- Built-in cable jacket seal.

Ratings

per ANSI/IEEE Standard 386

15kV Voltage Class

8.3 kV Max Phase-to-Ground - Operating Voltage

14.4kV Max Phase-to-Phase

95kV BIL - Impulse Withstand (1.2 x 50 microsecond wave)

34kV AC - One minute Withstand

53kV DC - 15 Minutes Withstand

11kV AC - Corona Extinction @ 3p.C.sensitivity

200Amp - Continuous and Loadbreak

10kA Sym - 10 Cycles Momentary & Fault Close

Applications

The 165LRJS is designed for connecting to and operating 15kV Class, 200 Amp distribution apparatus. It provides a convenient method to connect/disconnect cable and equipment on power distribution systems. The 165LRJS allows connection of cables with insulation diameters from .575" (14,6mm) to 1.220" (31,0mm) with only four elbow sizes. (#2 solid, 175 mil to 4/0 stranded, 260 mil).

The Elastimold 165LRJS Elbow Connector is a fully rated 15kV, 200 Amp Class loadbreak connector. It includes provisions for energized operation using standard hotstick tools allowing loadmake/break operation and a visible disconnect. It has a standard interface for connecting to 15kV, 200 Amp bushing inserts, junctions and operating accessories.

