

<b>PRODUCT SPECIFICATION SHEET</b>	<b>I T C</b>
<b>15kV 200A Loadbreak Insulated Cap</b>	<b>167DRG</b>
<b>w/ Ground Lead &amp; Insulated Cuff</b>	

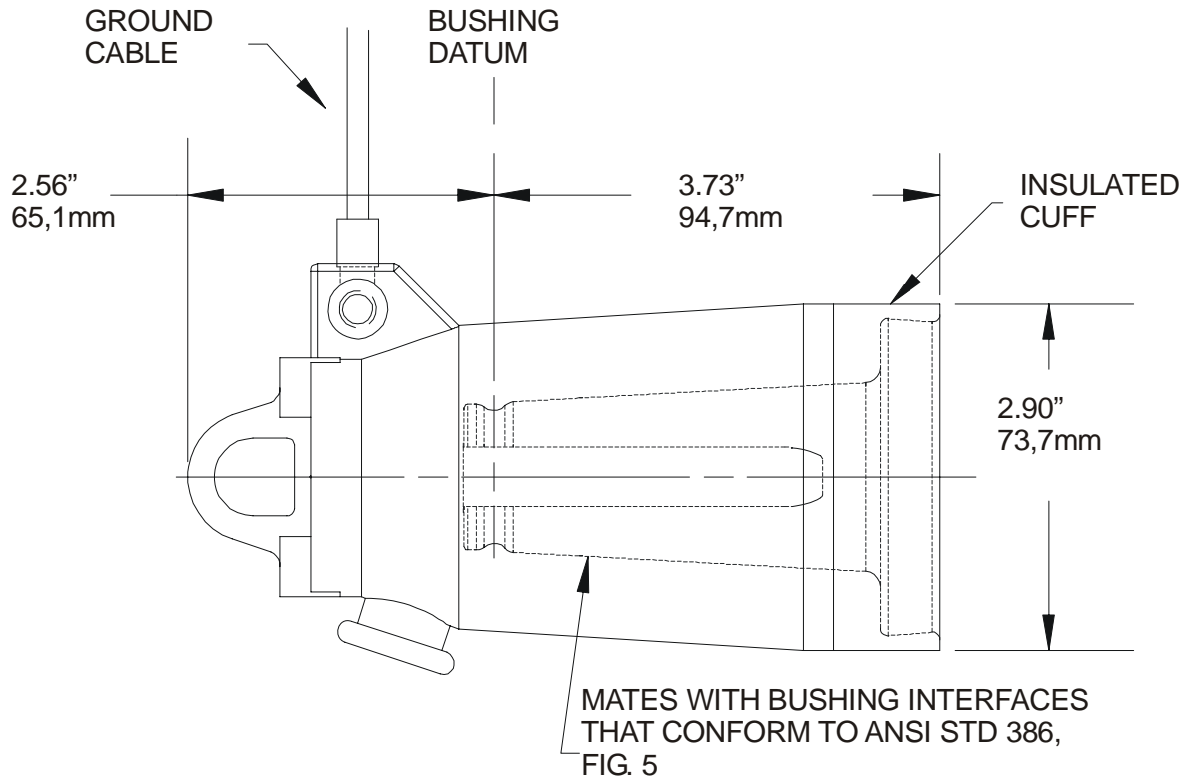

**Application:**

ELASTIMOLD 167DRG insulated caps (with insulated cuff) are fully shielded, fully submersible, hot stick operable, separable insulated connector designed for energized operation. They are suitable for use on 15kV class loadbreak systems. The 167DRG has an integral ground lead as part of the assembly, it is used to "dead-end" the following ELASTIMOLD mating products:

- \* 1601A4 bushing insert
- \* 1602A3R feed-thru insert
- \* 164FT feed-thru
- \* 164 series junctions

**Ratings**

per ANSI/IEEE Standard 386  
 15kV Voltage Class  
 8.3kV Max Phase-to-Ground - Operating Voltage  
 14.4kV Max Phase-to-Phase  
 95kV BIL - Impulse Withstand (1.2 x 50 microsecond wave)  
 34kV AC - One minute Withstand  
 53kV DC - 15 Minute Withstand  
 11kV AC - Corona Extinction @ 3p.C.sensitivity  
 200 Amp - Continuous and Loadbreak  
 10kA Sym - 10 Cycles Momentary & Fault Close

**Ordering Instruction:**

To order, specify number **167DRG** insulated cap.

The 167DRG insulated cap includes the following:

1 - Insulated cap	167DRG
1 - Grounding cable #14 AWG, 38"	5000-150-1
1 - Lubricant	82-08
1 - Installation instruction	IS-0892