

|  |               |
|--|---------------|
| <b>PRODUCT SPECIFICATION SHEET</b>         | <b>I T C</b>  |
| <b>25kV 200A Loadbreak Insulated Cap</b>   | <b>273DRG</b> |
| <b>w/ Ground Lead &amp; Insulated Cuff</b> |               |

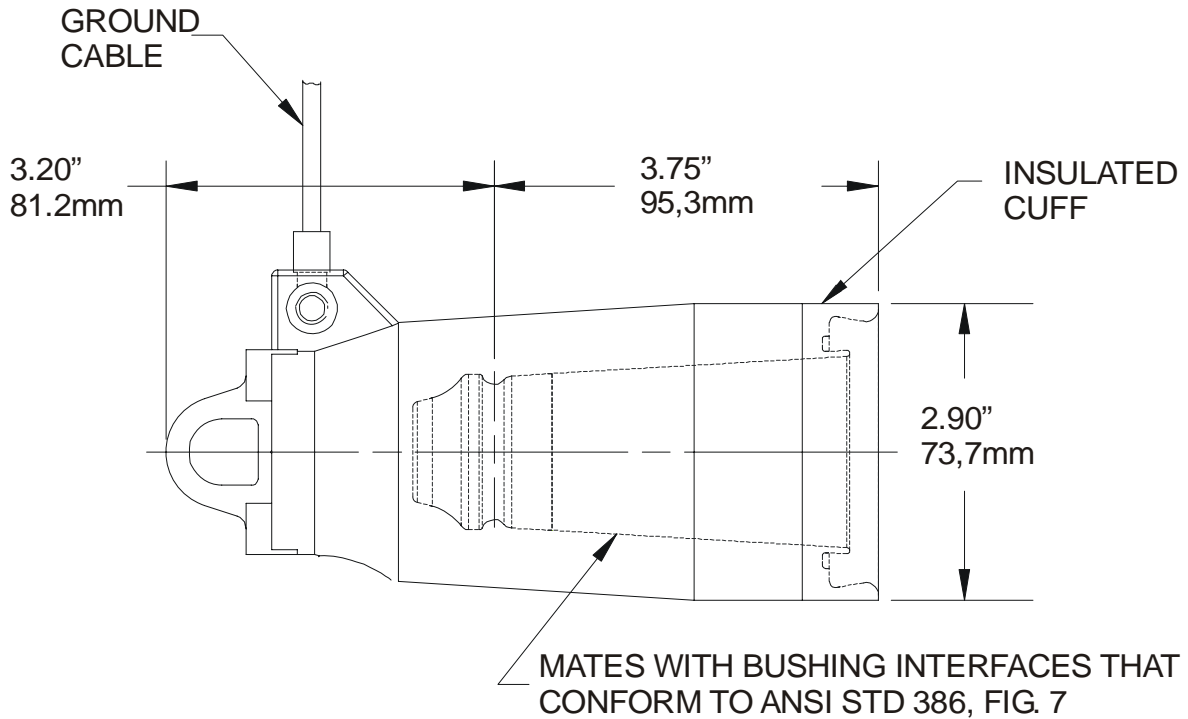

**Application:**

ELASTIMOLD 273DRG insulated caps (with insulated cuff) are fully shielded, fully submersible, hot stick operable, separable insulated connector designed for energized operation. They are suitable for use on 25kV class loadbreak systems. The 273DRG has an integral ground lead as part of the assembly. The 273DRG is used to "dead-end" the following ELASTIMOLD mating products:

- \* 2701A4 bushing insert
- \* 2702A1 feed-thru insert
- \* 274FT feed-thru
- \* 274 series junctions

**Ratings**

per ANSI/IEEE Standard 386  
 25kV Voltage Class  
 15.2kV Max Phase-to-Ground - Operating Voltage  
 26.3kV Max Phase-to-Phase  
 125kV BIL - Impulse Withstand (1.2 x 50 microsecond wave)  
 40kV AC - One minute Withstand  
 78kV DC - 15 Minutes Withstand  
 19kV AC - Corona Extinction @ 3p.C.sensitivity  
 200Amp - Continuous and Loadbreak  
 10kA Sym - 10 Cycles Momentary & Fault Close

**Ordering Instructions:**

To order, specify number **273DRG** insulated cap.

**The 273DRG insulated cap includes the following:**

- |                              |            |
|------------------------------|------------|
| 1 - Insulated cap            | 273DRG     |
| 1 - Gnd cable #14 AWG, 38"   | 5000-150-1 |
| 1 - Lubricant                | 82-08      |
| 1 - Installation instruction | IS-0894    |