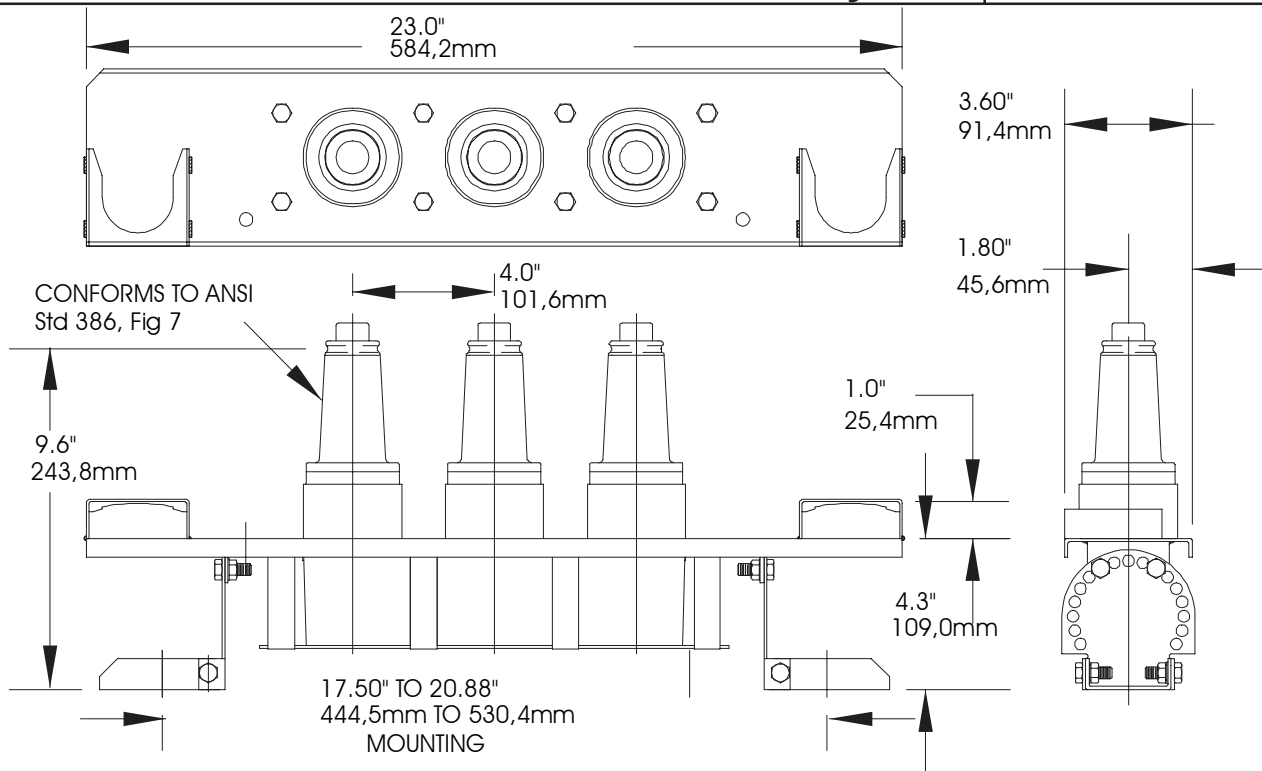

**PRODUCT SPECIFICATION SHEET**
**I T C**
**25kV 200A Loadbreak Junction - 3 Way**
**274J3**

ELASTIMOLD junctions are designed for subsurface, vault or padmount applications and can be used for sectionalizing, looping, tapping, and equipment bypass. Junctions are designed to mate with other ELASTIMOLD products including:

- 273LR elbow connector
- 274LR elbow connector
- 370GLR grounding elbow
- 370TR test rod
- 273/274DR insulated cap

ELASTIMOLD loadbreak junctions, provide a fully shielded, fully submersible, separable, insulated assembly designed for energized operation. They are suitable for use on 25-kV class distribution systems. And rated for 200-ampere loadmake/break operation. Junctions are equipped with universal brackets that accommodate curved or flat surfaces and provide tilt mounting angles from 0° to 90° in 15° increments.

### Ratings

per ANSI/IEEE Standard 386  
 25kV Voltage Class  
 15.2kV Max Phase-to-Ground - Operating Voltage  
 26.3kV Max Phase-to-Phase  
 125kV BIL - Impulse Withstand (1.2 x 50 microsecond wave)  
 40kV AC - One minute Withstand  
 78kV DC - 15 Minutes Withstand  
 19kV AC - Corona Extinction @ 3p.C.sensitivity  
 200 Amp - Continuous and Loadbreak  
 10kA Sym - 10 Cycles Momentary & Fault Close

### Ordering Instructions:

Specify **274J3** for 25kV, 200 Amp, 3-way Loadbreak Junction  
 Add "-5" at the end of the catalog number for junctions with "U" style mounting straps only.  
 Add "-6" at the end of the catalog number for bracket only with "U" strap and mounting hardware.

### The 274J3 3-way Junction kit contains the following:

1 - Basic Molded Junction	274J3-4
1 - Mounting Hardware	274J3-6
4 - U strap	163-159
3 - Protective shipping cap	2701-41
3 - Tube, lubricant	82-08
1 - Installation instruction	IS-274J2, J3, J4 1/98