

**Elastimold® Fused Elbows** combine the advantages of Full-Range Current-Limiting Fusing with the convenience of 15/25kV hot stick operable, loadbreak elbow switching.

This is the fastest, most cost effective way to improve the distribution system's reliability without adding a separate piece of switchgear or replacing existing sectionalizing cabinets. Simply replace existing 200 Amp tap elbows with Elastimold® Fused Elbows to protect light duty underground distribution systems including sub-loops, and radial taps.



Molded Fuse Products

FEATURE	BENEFIT/DESCRIPTION
EPDM Molded Rubber Deadfront Construction	Fully sealed and submersible Insulate, shield and eliminate exposed live parts
Split Center Section	Easy fuse replacement
Built-in Voltage test points or direct test ports	Quick and convenient blown fuse indication
Full-range current-limiting fusing with 50kA interrupting capability Rated 5kV Ungrounded to 25kV Grounded Wye 15/25kV hot stick operable, loadbreak elbow switching	Facilitates fusing of light duty underground distribution systems including sub-loops, radial taps, junctions, transformers, and other equipment

**CERTIFIED TESTS & PERFORMANCE**

Elastimold® fused elbows have been designed and tested per applicable portions of IEEE, ANSI, and other industry standards including:

**ANSI C37.40** Standard for Current-Limiting Fuse Service Conditions.

**ANSI C37.41** Standard for Current-Limiting Fuse Design & Testing.

**ANSI C37.47** Standard for Current-Limiting Fuse Ratings & Specifications.

**IEEE 386** Standard for Separable Connectors.

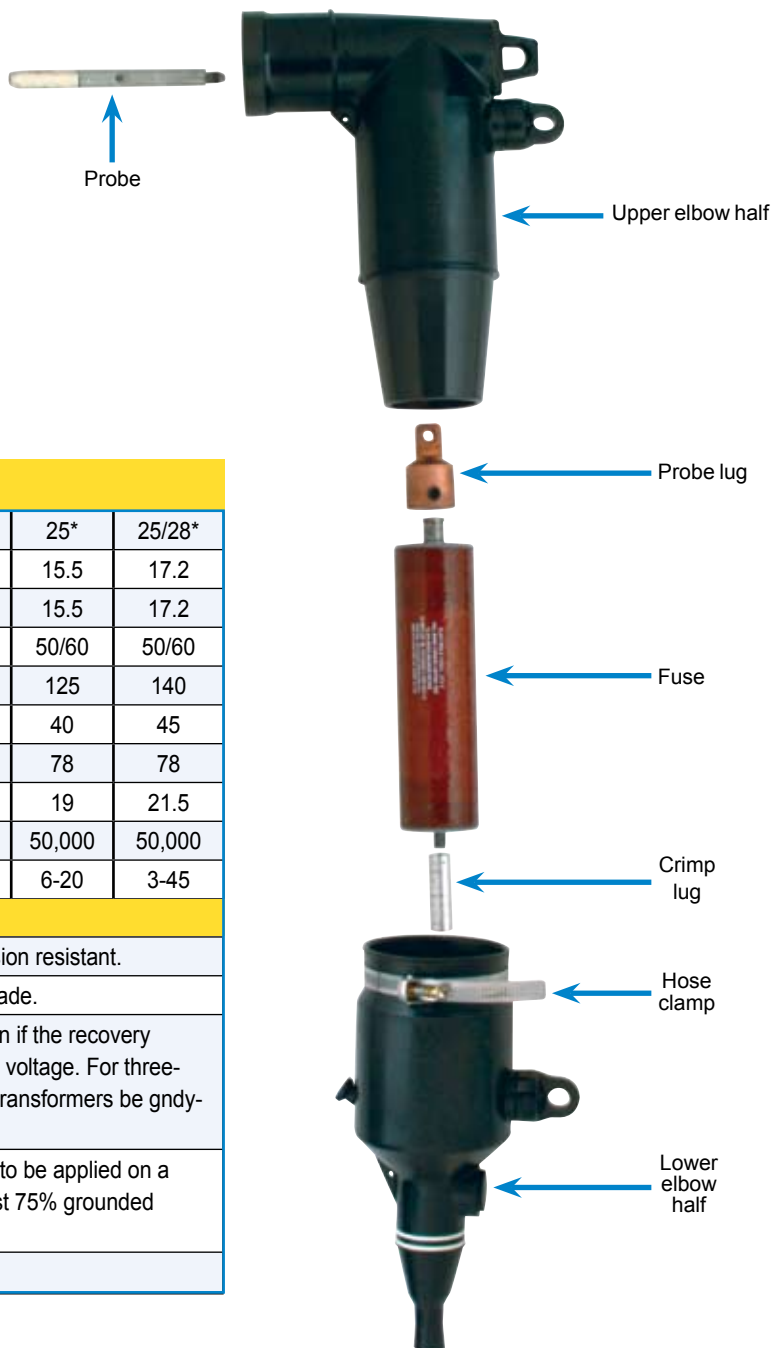

**RATINGS**

System Voltage Class (kV)	15	25*	25/28*
Nominal Fuse Voltage (kV)	8.3	15.5	17.2
Rated Maximum Fuse Voltage (kV)	10	15.5	17.2
Frequency (Hz)	50/60	50/60	50/60
BIL Impulse Withstand (kV)	95	125	140
One Minute AC Withstand (kV)	34	40	45
Fifteen Minute DC Withstand (kV)	53	78	78
Corona Extinction (kV)	11	19	21.5
Symmetrical Interrupting Capability (Amp)	50,000	50,000	50,000
Current Rating (Amp)	3-80	6-20	3-45

**APPLICATION INFORMATION**

Construction: Submersible, non-venting, deadfront, corrosion resistant.

Ambient Temperature Range: - 30 to +65 degrees centigrade.

Fuses are only suitable for the system voltage class shown if the recovery voltage across the fuse will not exceed its rated maximum voltage. For three-phase applications, this generally requires that protected transformers be gndy-gndy and have at least 50% grounded load.

\* The 15.5kV L-G rated fuse requires 75% grounded load to be applied on a 25kV system. The 17.2kV L-G rated fuse requires at least 75% grounded load to be applied on a 28kV system.

Fuse replacement requires the elbow to be de-energized.

Molded Fuse Products

**TABLE 31 – ELECTRICAL CHARACTERISTICS OF EFX-ELBOW FUSES**

System Voltage Class (kV)	Nominal Fuse Voltage Rating (kV)	Current Rating (Amps)	Fuse Catalog Number	Rated Maximum Voltage (kV)	Maximum Continuous Current (2) (6)			Peak Arc Voltage (kV) (5)	Minimum Melt I <sup>2</sup> t (AMP <sup>2</sup> ·SEC)	Maximum Total I <sup>2</sup> t (3),(4) (AMP <sup>2</sup> ·SEC)
					25°C	40°C	65°C			
15	8.3	3	EFX083003-E	10.0	4.3	4.2	3.9	30	100	350
		6	EFX083006-E		9.5	9.0	8.5	32	620	2,700
		8	EFX083008-E		11.5	11.0	10.5	28	800	4,000
		10	EFX083010-E		14.0	13.5	13.0	28	800	4,000
		12	EFX083012-E		19.0	18.5	17.5	26	920	8,000
		18	EFX083018-E		21.0	20.0	19.0	26	1,310	9,500
		20	EFX083020-E		26.0	25.0	24.0	26	1,620	11,000
		25	EFX083025-E		34.0	33.0	31.0	26	3,660	22,000
		30	EFX083030-E		37.5	36.5	34.5	26	5,250	30,000
		40	EFX083040-E		43.0	42.0	40.0	26	8,700	50,000
		45	EFX083045-E	49.0	47.0	45.0	26	12,800	70,000	
				65	EFX083065-E	8.8	70.0	68.0	64.5	23
		80	EFX083080-E	80.0	77.5		73.5	22	51,200	280,000
25	15.5	6	EFX155006-E	15.5	8.5	8.0	7.7	52	620	3,000
		8	EFX155008-E		10.5	10.0	9.5	40	800	4,300
		10	EFX155010-E		13.0	12.5	12.0	40	800	4,300
		12	EFX155012-E		16.0	15.5	15.0	38	920	8,000
		18	EFX155018-E		20.0	19.5	18.5	38	1,620	13,000
		20	EFX155020-E		23.5	22.5	21.5	38	2,200	16,500
25/28	17.2	3	EFX172003-E	17.2	4.3	4.2	3.9	51	100	510
		6	EFX172006-E		9.5	9.0	8.5	54	620	3,250
		8	EFX172008-E		11.5	11.0	10.5	46	800	4,600
		10	EFX172010-E		14.0	13.5	13.0	46	800	4,600
		12	EFX172012-E		18.0	17.5	16.5	43	920	8,500
		18	EFX172018-E		20.0	19.5	18.5	45	1,310	10,000
		20	EFX172020-E		24.0	23.0	22.0	45	1,620	12,500
		25	EFX172025-E		31.5	30.5	29.0	45	3,660	27,500
		30	EFX172030-E		35.5	34.5	32.5	45	5,250	37,500
		40	EFX172040-E		41.0	40.0	38.0	45	8,700	62,500
		45	EFX172045-E		46.0	45.0	42.5	45	12,800	87,500

**NOTES:**

1. Designs have a 50,000 Amps rms. Symmetrical Rating (except 3A 17.2kV which was tested at 44kA maximum).
2. Fuses have a Rated Maximum Application Temperature of 65°C (RMAT is the maximum temperature of the air, in contact with the elbow housing, at which they have been shown to be suitable for use).
3. Tabulated Maximum Total I<sup>2</sup>t values are for currents of 50,000 amperes at the nominal voltage of the fuse. Values for 8.3kV fuses at 10kV are approximately 30% higher. Values for 17.2kV fuses at 15.5kV are approximately 20% lower.
4. Maximum total I<sup>2</sup>t values are reduced for currents below 50,000 A. For example, at 10,000 A, maximum total I<sup>2</sup>t values are approximately 15% less than the published values.
5. Peak arc voltages quoted are for 50,000 A currents at the rated maximum voltage listed. Reduced currents and voltages will reduce the peak arc voltage. Consult the factory for further information.
6. Maximum continuous currents at ambient temperatures other than those listed may be determined by derating the fuses by 0.2% per degree C over 25°C. For example: At 40°C the derating would be 15 x .2 = 3%, making the maximum continuous current of a 17.2kV 25A fuse 31.5 x .97 = 30.5A.
7. Time-current characteristic curves are published at 25°C. Reduction in the long time melting current of the fuses (approximately one hour and longer) due to higher ambient temperatures is the same as described above for "maximum continuous currents".

**TABLE 32 – RECOMMENDED EFX–E: ELBOW FUSE AT 40°C AMBIENT TEMPERATURE**

Fuse Voltage	Recommended Fuse Current Ratings (Amperes)															
	8.3kV								15.5kV (17.2kV)							
	Transformer 1-Phase Voltage Rating (kV) Phase-to-Ground															
1-Phase Transformer kVA	2.4		4.16		4.8		7.2		7.62		12		14.4		16	
	A	B	A	B	A	B	A	B	A	B	A	B	A	B	A	B
10		6		6 <sup>a</sup>		3		3		3		6 <sup>a</sup>		6 <sup>a</sup>		(3) <sup>a</sup>
15		10		6		6 <sup>a</sup>		3		3		6 <sup>a</sup>		6 <sup>a</sup>		(3) <sup>a</sup>
25	12	20		8		8		6		6		6 <sup>a</sup>		6 <sup>a</sup>		(3)
37.5	20	25		12		12		8		8		6		6 <sup>a</sup>		(6) <sup>a</sup>
50	25	40	18	20	12	20	10	12		10		6		6		(6) <sup>a</sup>
75	45	65	20	30	20	25	12	20	12	18		10		8		(8)
100	65	80	30	45	25	40	18	25	18	25	12	18	10	12		(10)
167			65	80	45	65	25	45	25	45	18	(25)	18	20	(12)	(20)
250			80		80		45	65	45	65	(25)	(45)	20	(30)	(20)	(30)
333							65		80		(40)		(30)	(45)	(25)	(45)
500													(45)		(45)	

**TABLE 33 – RECOMMENDED EFX–E: ELBOW FUSE AT 40°C AMBIENT TEMPERATURE**

Fuse Voltage	Recommended Fuse Current Ratings (Amperes)																	
	8.3kV								15.5kV (17.2kV)									
	Transformer 3-Phase Voltage Rating (kV) Phase-to-Phase																	
3-Phase Transformer kVA	2.4		4.16		4.8		7.2-7.96		8.32		12.47		13.2-14.4		20.8 <sup>b</sup>		22.9-24.9 <sup>b</sup>	
	A	B	A	B	A	B	A	B	A	B	A	B	A	B	A	B	A	B
15		6		3		3		3 <sup>a</sup>		3 <sup>a</sup>		6 <sup>a</sup>		6 <sup>a</sup>		6 <sup>a</sup>		(3) <sup>a</sup>
22.5		8		6 <sup>a</sup>		6 <sup>a</sup>		3		3		6 <sup>a</sup>		6 <sup>a</sup>		6 <sup>a</sup>		(3) <sup>a</sup>
30	10	12		6		6		6 <sup>a</sup>		3		6 <sup>a</sup>		6 <sup>a</sup>		6 <sup>a</sup>		(3) <sup>a</sup>
45	12	20		10		8		6		6 <sup>a</sup>		6 <sup>a</sup>		6 <sup>a</sup>		6 <sup>a</sup>		(3) <sup>a</sup>
75	20	30	12	20		12		8		8		6		6		6 <sup>a</sup>		(3)
100	30	45	18	25	18	20		12		10		8		8		6 <sup>a</sup>		(6) <sup>a</sup>
112.5	40	65	20	25	18	25		12		12		8		8		6		(6) <sup>a</sup>
150	45	80	25	40	20	30	18	20	12	20	10	12	10	12		6		(6)
200	65	80	40	65	30	45	20	25	18	25	12	18	12	18	8	10		(8)
225	80		45	65	40	65	20	30	20	25	12	20	12	18	8	10		(10)
300			65	80	45	80	30	45	25	40	18	(25)	18	(25)	12	18		(12)
500					80		65	80	45	80	(30)	(45)	(30)	(45)	18	(25)	(18)	(25)
750							80		80				(45)		(25)	(45)	(25)	(40)
1000															(40)		(40)	

**NOTES FOR TABLES 32 AND 33:**

Column A = 140-200% of transformer rating and Column B = 200-300% of transformer rating.

- Ratings in parenthesis are 17.2kV fuses.
  - 8.3kV 3-45A fuses and 15.5kV 6-20A fuses are used in the small elbow housing. 8.3kV 65-80A fuses and 17.2kV 3-45A fuses are used in the large elbow fuse housing.
  - Recommended fuses meet inrush criteria of 12 times transformer full load current for 0.1 second and 25 times transformer full load current for 0.01 second. Fuses also meet cold load pickup criteria of 6 times transformer full load current for 1 second and 3 times transformer full load current for 10 seconds.
- a Fuse allows greater than 300% of transformer rating.
- b Recommendations limited to gndY-gndY transformers with no more than 50% delta connected secondary load, and involve certain assumptions. Phase-to-ground rated fuses are frequently recommended for gndY-gndY three phase transformers.

Molded Fuse Products

### ORDERING INFORMATION FOR FUSE HOUSINGS

YYY A **FLR** H - WØX

#### NOMINAL FUSE VOLTAGE RATING

168	8.3kV
274	15.5kV
274	17.2kV

#### FUSE TEST PORT

A	Two Direct Test Ports
Blank	Two Capacitive Test Points

#### HOUSING

1	Small*
3	Large**

#### CONDUCTOR SIZE

Stranded / Comp.	Solid / Compact	Size (AWG)
180	-	6
200	190	4
220	210	2
230	220	1
240	230	1/0
250	240	2/0
260	250	3/0
270	260	4/0

#### CABLE INSULATION DIAMETER (IN.)

	0.575" - 0.740"	15mm - 19mm
A	0.575" - 0.740"	15mm - 19mm
B	0.635" - 0.905"	16mm - 23mm
C	0.805" - 1.060"	20mm - 27mm
D	0.890" - 1.220"	25mm - 31mm

\* Small Housing is used with 8.3kV (3-45Amp) and 15.5kV (6-20Amp) rated fuses

\*\* Large Housing is used with 8.3kV (65 and 80Amp) and 17.2kV (3-45Amp) rated fuses

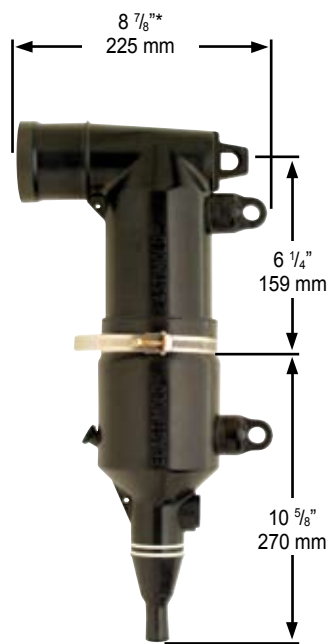

168FLR1



274FLR1

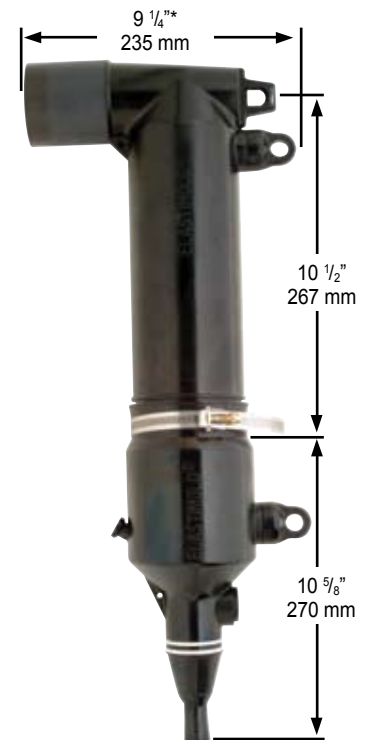

274FLR3  
168FLR3

#### NOTES:

- All dimensions rounded up to the nearest eighth inch.
- Also available with direct test port.
- Dimensions for Direct Test Port units are \* 10 1/4 (260mm) or \*\* 10 5/8 (270mm)
- 168FLR3 uses a large housing with a 15kV, 200 Amp elbow interface

**ORDERING INFORMATION FOR FULL-RANGE CURRENT-LIMITING FUSES**

**EFX** **YYY** **AAA** - **E**

**VOLTAGE RATING**

083	8.3kV
155	15.5kV
172	17.2kV

**AMPERAGE RATING**

003	3 Amps	8.3 / 17.2kV
006	6 Amps	8.3 / 15.5 / 17.2kV
008	8 Amps	8.3 / 15.5 / 17.2kV
010	10 Amps	8.3 / 15.5 / 17.2kV
012	12 Amps	8.3 / 15.5 / 17.2kV
018	18 Amps	8.3 / 15.5 / 17.2kV
020	20 Amps	8.3 / 15.5 / 17.2kV
025	25 Amps	8.3 / 17.2kV
030	30 Amps	8.3 / 17.2kV
040	40 Amps	8.3 / 17.2kV
045	45 Amps	8.3 / 17.2kV
065	65 Amps	8.3kV
080	80 Amps	8.3kV

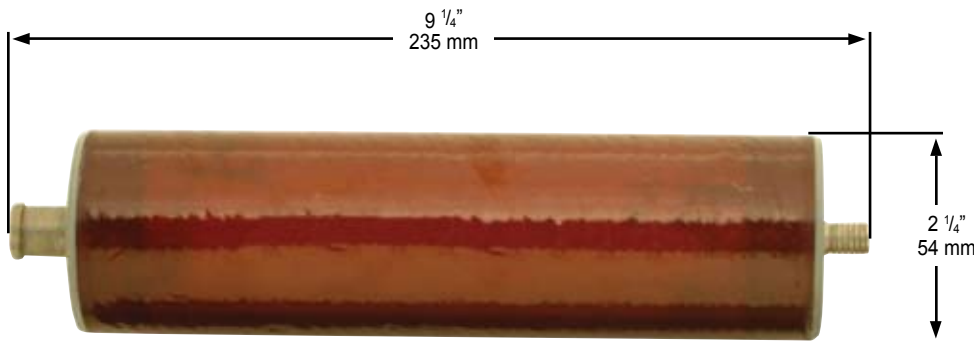

8.3/15.5 kV Fuse

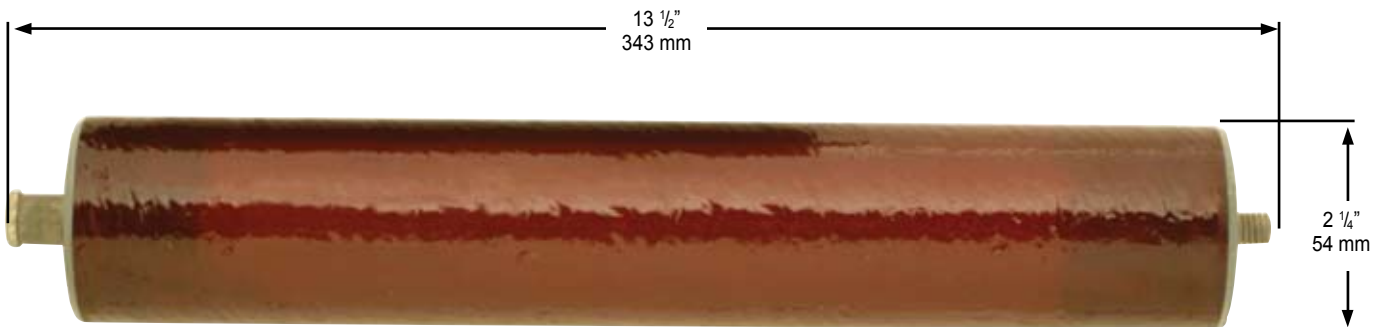

8.3/17.2kV Fuse

**NOTE:**

- All dimensions rounded up to the nearest eighth inch.

Molded Fuse Products