

### OLM Standard Features

**AccQTrip™ Logic Circuitry** In voltage reset units prevents false indications due to inrush currents, cold load pickup, and overloading

**AccQClamp™ Mounting Provision** Universal one-size-fits-all design automatically adjusts

**High/Low Trip Setting Selection** No minimum load current requirement, and no load surveys needed

**Trip Response .001 Seconds** Coordinates with current limiting fuses, as well as other protection devices

**Internal Magnetic Shielding** Prevents adjacent phase effects

**Magnetically Latched Flag Indication** Flag Indication will not change states due to shock or vibration

**Light Weight, Compact and Sealed**

**Overhead Line Fault Indicators** aid in locating faulted circuits and equipment on overhead distribution systems. Indicators are self powered and consist of a solid state current sensor connected to a faulted circuit display. Designs incorporate advanced circuit logic, monitoring system protection operation and prevent indicator tripping unless an overcurrent condition is followed by a loss of system voltage. Trip and reset operations are automatic and the same indicator may be used for 5kV thru 35kV line-to-ground applications.

Units are designed for direct installation to the overhead line using a spring loaded, over center, toggle clamp mounting provision. The clamp accommodates conductors ranging from .4 to 2.2 inches in diameter and includes retainer pads to prevent slip and twist. The clamp positions the conductor at a constant distance from the current sensor, maintaining indicator trip accuracy over the entire range of conductors. Designs are compact, sealed and corrosion resistant.



**OLMVF Model**

**OLMVL OLMVOL Model**

**OLMTL-LT Model**

### Basic Operation

A faulted circuit produces an associated magnetic field which closes a reed switch in the indicator resulting in a tripped display.

**Trip**

response occurs in .001 seconds allowing the fault indicator to properly coordinate with all types of circuit protection schemes including current limiting fuses.

To eliminate confusing false trips, indicators are equipped with inrush, overload and cold load pick up restraint circuitry as standard. Current sensors are constructed with internal shielding to prevent inadvertent tripping when located in close proximity to adjacent phases.

### SPECIFICATIONS FOR OLM VOLTAGE OPERATED, TIME RESET, LED DISPLAY: MODEL OLMVOL

Nominal Voltage	4.16-60kV (L-L)
Nominal Trip Ratings	Low, 400 Amp; High, 800 Amp
Trip Response Time	1mS
Fault Clearing Time <sup>1</sup>	.001 – 30 Sec. Subsequent To Arming
Maximum Surge Level	25kA 10 Cycles 60 Hz
Effect of Adjacent Phase	Internal Shielding Prevents Adjacent Phase Effects
Inrush/Backfeed Restraint	100mS (Disable Delay)
Load Current Requirements	None
Power Up Requirement	6 Minutes @ 5kV
Display Type	Flashing Super Bright LED
Flash Rate	30 Flashes per Minute
LED Display Time	4 Hour – Standard
Reset Time	4 Hour-Standard (longer times available upon request)
Power Source <sup>3</sup>	3.6 volt Lithium Thyonil Chloride Battery
Battery Capacity	2.4 Ah
Battery Operating Life	1200 Flash Hours Minimum
Battery Storage Life	15-20 Years
Temperature Range	-40°C To +85°C
Housing Material	Mounting Boot – EPDM Conductive Rubber Housing Body – UV Stabilized Polycarbonate Polymer
Weight	258 Grams

### SPECIFICATIONS FOR OLM VOLTAGE RESET, FLAG DISPLAY: MODEL OLMVF

Nominal Voltage	4.16-60kV (L-L)
Nominal Trip Ratings	Low, 400 Amp; High, 800 Amp
Trip Response Time	1mS
Fault Clearing Time <sup>1</sup>	.001 – 30 Sec. Subsequent To Arming
Maximum Surge Level	25kA 10 Cycles 60 Hz
Effect of Adjacent Phase	Internal Shielding Prevents Adjacent Phase Effects
Inrush Restraint Response	100mS (Disable Delay)
Load Current Requirements	None
Display Type	Mechanical Flag
Minimum Reset Voltage	5KV (Beginning Initializing Sequence)
Voltage Reset Time	6 Minutes @ 5KV
Power Source	Volt Test Point Powered
Temperature Range	-40°C To +85°C
Housing Material	Mounting Boot – EPDM Conductive Rubber Housing Body – UV Stabilized Polycarbonate Polymer
Weight	258 Grams

### SPECIFICATIONS FOR OLM VOLTAGE RESET, LED DISPLAY: MODEL OLMVL

Nominal Voltage	4.16-60kV (L-L)
Nominal Trip Ratings	Low, 400 Amp; High, 800 Amp
Trip Response Time	1mS
Fault Clearing Time <sup>1</sup>	.001 – 30 Sec. Subsequent To Arming
Maximum Surge Level	25kA 10 Cycles 60 Hz
Effect of Adjacent Phase	Internal Shielding Prevents Adjacent Phase Effects
Inrush Restraint Response	100mS (Disable Delay)
Load Current Requirements	None
Power Up Requirement	6 Minutes @ 5kV
Display Type	Flashing Super Bright LED
Flash Rate	30 Flashes per Minute
LED Display Time	4 Hour – Standard
Voltage Reset Time	6 Minutes @ 5kV
Power Source <sup>3</sup>	3.6 volt Lithium Thyonil Chloride Battery
Battery Capacity	2.4 Ah
Battery Operating Life	1200 Flash Hours Minimum
Battery Storage Life	15-20 Years
Temperature Range	-40°C To +85°C
Housing Material	Mounting Boot – EPDM Conductive Rubber Housing Body – UV Stabilized Polycarbonate Polymer
Weight	258 Grams

### SPECIFICATIONS FOR OLM TIME RESET, LED DISPLAY: MODEL OLMTL<sup>2</sup>

Nominal Voltage	4.16-60kV (L-L)
Nominal Trip Ratings	Low, 400 Amp; High, 800 Amp
Trip Response Time	1mS
Maximum Surge Level	25kA 10 Cycles 60 Hz
Effect of Adjacent Phase	Internal Shielding Prevents Adjacent Phase Effects
Power Up Requirement	None
Display Type	Flashing Super Bright LED
Flash Rate	30 Flashes per Minute
Reset Time	4 Hour – Standard
Power Source <sup>3</sup>	3.6 volt Lithium Thyonil Chloride Battery
Battery Capacity	2.4 Ah
Battery Operating Life	1200 Flash Hours Minimum
Battery Storage Life	15-20 Years
Temperature Range	-40°C To +85°C
Housing Material	Mounting Boot – EPDM Conductive Rubber Housing Body – UV Stabilized Polycarbonate Polymer
Weight	258 Grams

**NOTES:**

- 1) Prevents false trips due to short time interruptions without loss of voltage.
- 2) Inrush restraint is standard on voltage reset models. It is not available on time reset models.
- 3) Battery powers LED and it is active only when LED is ON. Lithium Thyonil Chloride batteries provide accurate indication throughout the entire temperature range.
- 4) Certified per ANSI/IEEE Standard 495-1986

# PROTECTION AND CONTROL

## Overhead Line Mounted

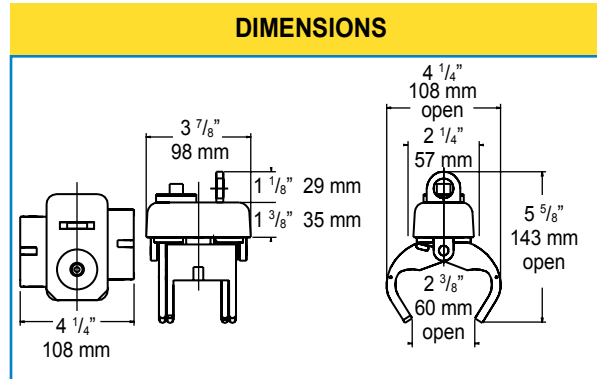
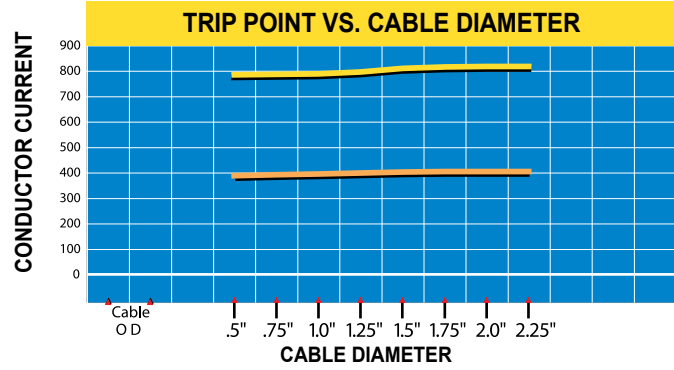
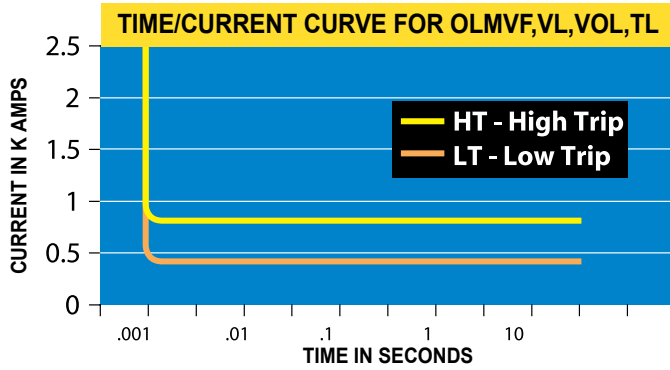

### ORDERING INFORMATION

#### CATALOG PREFIX

Catalog Number	Description	Reset Operation
OLMTL	Time Reset with LED Display	Indicator auto-resets to normal after a four-hour time duration. Indicator may also be manually reset using an FTT test tool.
OLMVF	Voltage Reset with Flag Display	Indicator auto-resets to normal after system voltage restoration. Reset requires 5kV minimum voltage to operate. Reset operation time is proportional to system voltage.
OLMVL	Voltage Reset with LED Display	Example: at 15kV, reset occurs 30 seconds after system voltage restoration.
OLMVOL	Voltage Operated, Time Reset, LED Display	Indicator auto-resets after a four-hour time duration. Longer time resets are available upon request.

#### CATALOG SUFFIX

Catalog Number	Description
LT	All fused taps use LOW trips ratings. For 200 Amp. URD applications, use LOW trip rating
HT	For 600 Amp. URD applications, use HIGH trip rating

For overhead bulk feeder applications, use HIGH or LOW trip ratings (whichever is greater than the minimum pickup setting of the related protection device).

AccQTrip™ and AccQClamp™ are trademarks of Quality Indications, Inc.