

PRODUCT SPECIFICATION SHEET	I T C
25kV 200A Load-break Bushing Insert	2701A4

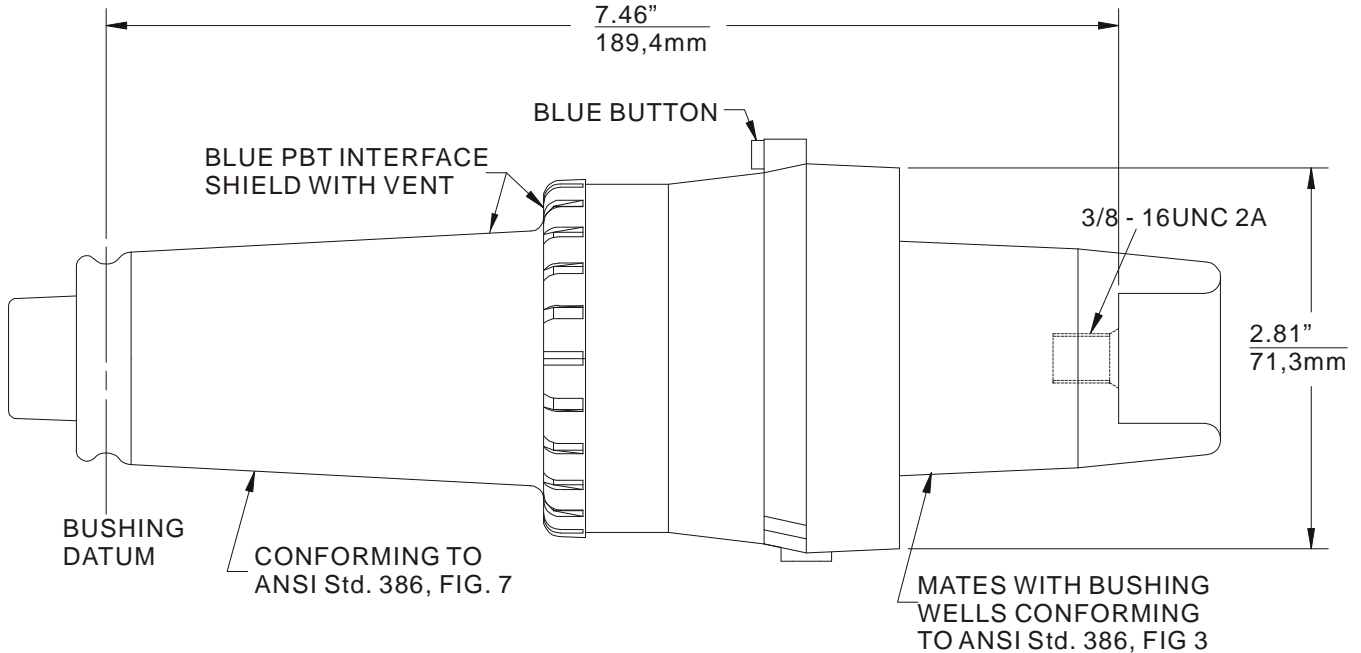

The Elastimold 2701A4 bushing insert is fully rated with a 25kV class, 200 Amp load break bushing interface. The load-break bushing insert fits a standard ANSI bushing well interface and becomes the apparatus bushing interface for elbow connections.

Features

- 25kV 200 Amp loadbreak rated.
- Includes hex-broach for torque installation.
- Peroxide-cured insulation and jacket.
- Provision for ground wire connection.
- Blue PBT interface shield with vent.

Ordering Instructicon:

To order, specify number **2701A4** bushing insert.

The 2701A4 bushing insert includes the following:

- | | |
|------------------------------|---------|
| 1 – bushing insert | 2701A4 |
| 1 – Protective shipping cap | 2701-41 |
| 1 – Lubricant | 82-08 |
| 1 – Installation instruction | IS-0748 |

Ratings

- per ANSI/IEEE Standard 386
- 25kV Voltage Class
- 15.2kV Max Phase-to-Ground - Operating Voltage
- 26.3kV Max Phase-to-Phase
- 125kV BIL - Impulse Withstand (1.2 x 50 microsecond wave)
- 40kV AC - One minute Withstand
- 78kV DC - 15 Minutes Withstand
- 19kV AC - Corona Extinction @ 3 pC sensitivity
- 200 Amp - Continuous and Loadbreak
- 10kA Sym - 10 Cycles Momentary & Fault Close

Applications

It may be used as the bushing interface for connecting shielded cable to the following:

- | | |
|----------------------------|--------------|
| * Sub-surface transformers | * Generators |
| * Pad mounted transformers | * Switchgear |
| * Regulators | * Reclosers |

Designed for use as an apparatus bushing interface, the 2701A4 is easily installed in an ELASTIMOLD universal bushing well and mated with an appropriate ELASTIMOLD product.